

CLARA TENSION SHOWER CADDY

ASSEMBLY INSTRUCTIONS

READ ALL INSTRUCTIONS FIRST BEFORE STARTING

STEP 1 - ORGANIZATION

Confirm all components as shown below and make sure all parts are included.

Note: Part E - The spring is stored inside one of the metal tubes.

Remove spring from inside tube.

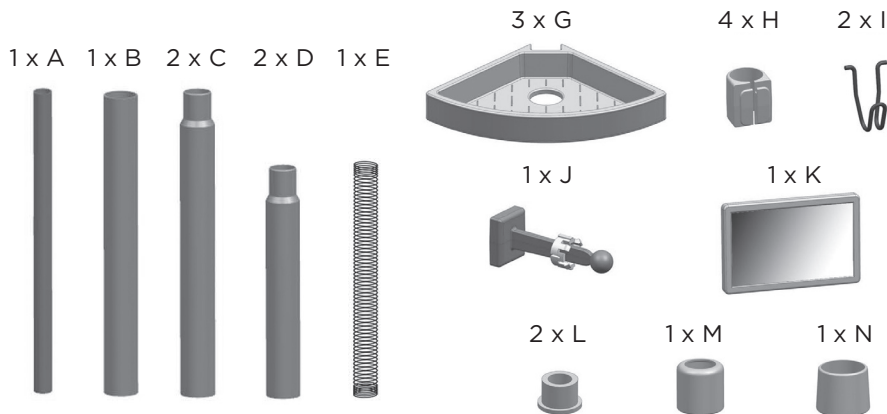

STEP 2 - PREPARATION

Measure the space you will be installing the shower tower into first so you know the final height you need to assemble the unit to before you begin.

NOTE: ALL PIECES MAY NOT BE REQUIRED, DEPENDING ON ASSEMBLY LENGTH.

For tub to ceiling or lower shower ceiling heights discard parts C and /or D as required.

The greater the tension the more stable the shower tower will be when assembled.

You should be expecting the final installed tension rod to project approximately 8" - 9" (20cm - 23 cm) above the fixed pole assembly it can project more or less and still function. These dimensions are just a guideline and are based on the average installation. They have to be used as a guide only and not used as rules.

IMPORTANT: The user has to be aware of the condition of the space they are installing the tower into.

Maximum compression of the tension rod could cause the rod to puncture poor quality or rotten ceilings.

We cannot be responsible for the condition or quality of the spaces this item is installed into.

The amount of upward pressure based on the compression of the tension rod and the final height of the tension rod is ultimately up to you the customer's discretion.

Keep this in mind when assembling the shower tower.

STEP 3 - POLE ASSEMBLY

Once you know the required height you will need to build to, select and assemble parts B and C as required.

Finish the pole by adding Part L on the top. (Refer to the assembly master diagram on the right hand side.)

Place part N (the plastic foot) onto the bottom pole.

Note the unit will come apart easily at this point as the tension rod assembly has not been assembled and put in place yet.

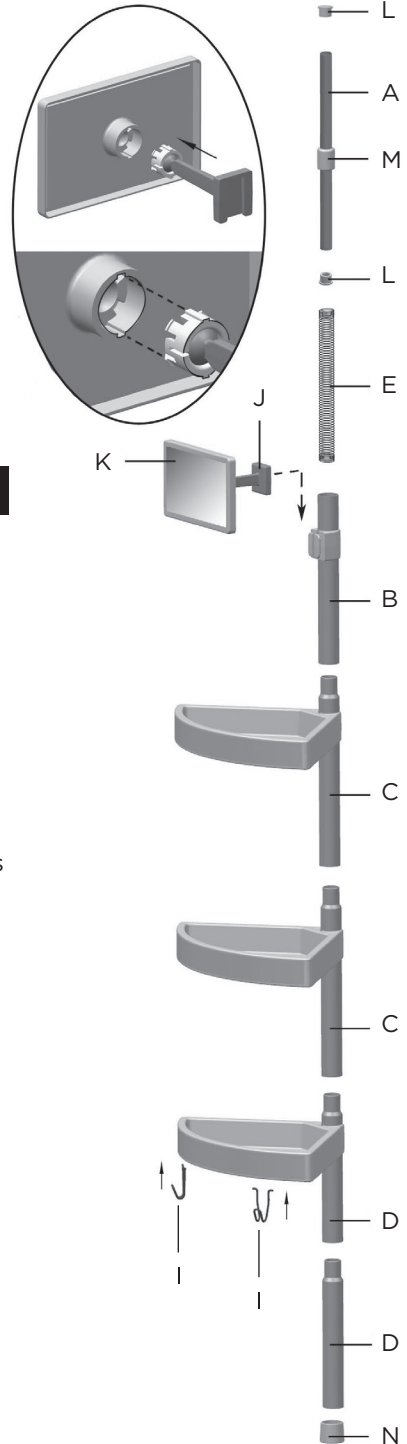

STEP 4 - ADDING SHELVES

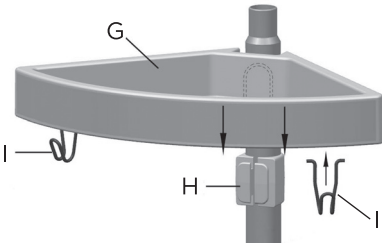

This tower comes with 1 mirror and 3 shelves that require assembly. (Please refer to the illustrated instructions above.)

Decide roughly how you want to distribute the shelves based on your needs.

Place part H (plastic locking ring) at your desired spacing along the assembled pole.

Move the locking ring up or down the pole until you can feel it catch on one of the horizontal grooves. You will notice the ring fits snug when in position.

IMPORTANT NOTE: Begin with the bottom shelf and work upward. Secure 1 plastic ring at a time and slide the pre assembled shelf down the pole and over the plastic locking ring until it is secure.

STEP 5 - TENSION ROD ASSEMBLY

A. Slide part M (the plastic collar) on part A (the metal tension rod.)

Affix plastic cap and foot parts L to the top and bottom of part A (the metal tension rod.)

You should now have 3 plastic parts affixed to part A (the metal tension rod.) Part M (the plastic collar) should be held stabilized in the bottom of the part A.

B. Insert one part A (the plastic tube) with the hollow end facing down inside of part B on the pole assembly.

Then insert part E the spring into part B.

Finish by inserting the Part C (the plastic tube) into part B. (On top of the already inserted part E the spring).

Make certain it is inserted with the hollow end facing down as well.

C. Now insert the assembled part A (the tension rod with 3 plastic parts affixed to it) into part B on the pole assembly.

Slide part L the plastic collar into the top of part A pushing the collar securely into place.

The tension rod should now be projecting out of the top of the assembly.

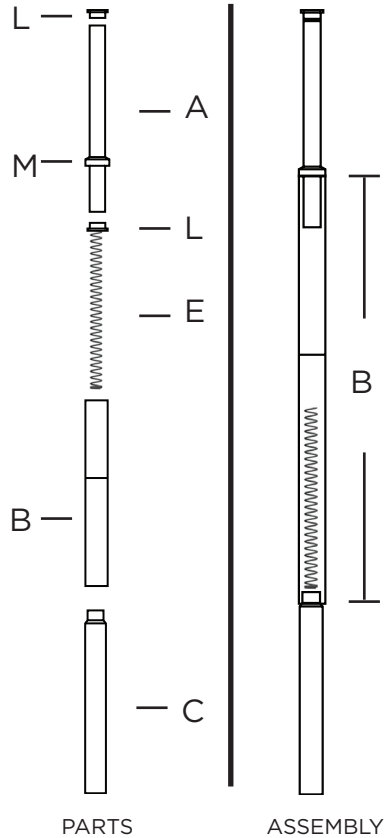

STEP 6 - INSTALLATION

To install the assembled shower tower place the top of the tension rod against the ceiling. While keeping tension on the spring by pushing upwards slide the bottom of the assembled unit into place so the tower is vertical and secure.

Note: If the area you are installing the tower into is such a dimension that you cannot achieve the correct height by discarding parts C and or D of the pole assembly the unit can be custom fit. This can be achieved by cutting one of the poles at the bottom on one of the grooved pole lines with a hacksaw.

Important: This should only be done once all pole combinations have been tested.

Once the item is cut the goods cannot be returned to the retailer.