

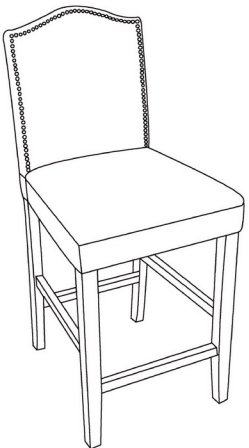









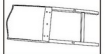

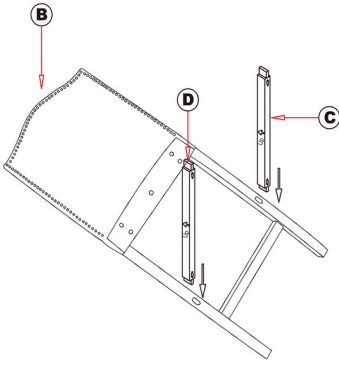
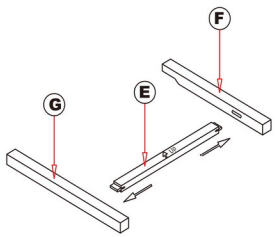
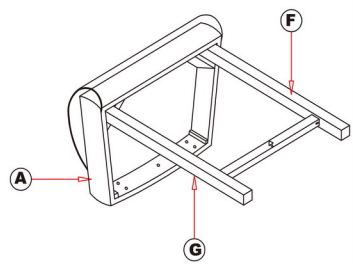
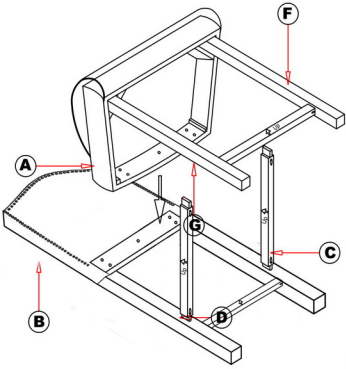
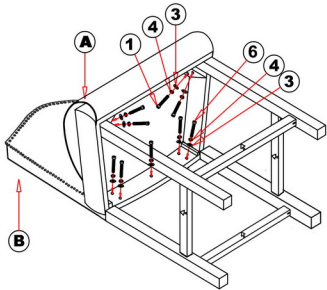
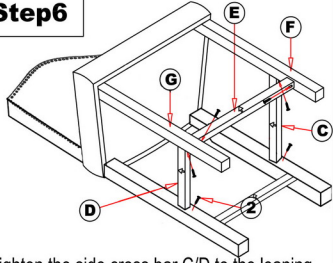

Assembly Instruction		Parts List			
		Parts ID	Image	Description	Qty
		A		Chair Cushion	1
		B		Chair Backrest	1
		C		Side cross bar (Left)	1
		D		Side cross bar (Right)	1
		E		Front cross bar	1
		F		Front Leg (Left)	1
		G		Front Leg (Right)	1
		Hardware Parts			
		1		M8x60mm	4
		2		Screw 4.2x35mm	6
		3		Washers	9
		4		Spring Washer	9
		5		Allen key	1
		6		M8x50mm	5

1. When assembling, two or more adults are required.
2. DO NOT TIGHTEN ANY SINGLE BOLTS OR NUTS BEFORE ALL BOLTS & NUTS IN THE ASSEMBLED POSITION.
3. Please check bolts regularly and tighten if needed.
4. Spot Clean by soft damp cloth.
5. Keep this Manual for future reference.

Step1	Step2	Step3
 <p>Insert the cross bars C/D onto the backrest B.</p>	 <p>Insert the cross bar E onto the front legs F/G.</p>	 <p>Put front legs F/G onto seat A.</p>

Step4	Step5	Step6
 <p>Put the seat A and front legs F/G onto the leaning back B and side cross bar C/D, press the end of the side cross bar C/D into the front legs F/G and make sure the hole on seat A align with the hole of leaning back B.</p>	 <p>Tighten the front legs F/G to the seat A with bolts 1, spring washers 3 & 4 using Allen Key 5, then attached the seat A to leaning back B with bolts 7, spring washers 3 & 4 using Allen Key 5.</p> <p>Do not fully tighten front legs F/G to the seat A in this assembly step.</p>	 <p>Tighten the side cross bar C/D to the leaning back B and the front legs F/G with screws 2 using screw driver.</p> <p>Tighten the front cross bar E to the front legs F/G with screws 2 using screw driver.</p> <p>Then fully tighten the front legs on the step 5.</p>
		<p>Finish</p> 