

Ax1Pc / Mcx

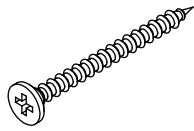

Bx2Pcs / Mcx

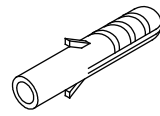

Cx2Pcs / Mcx

1

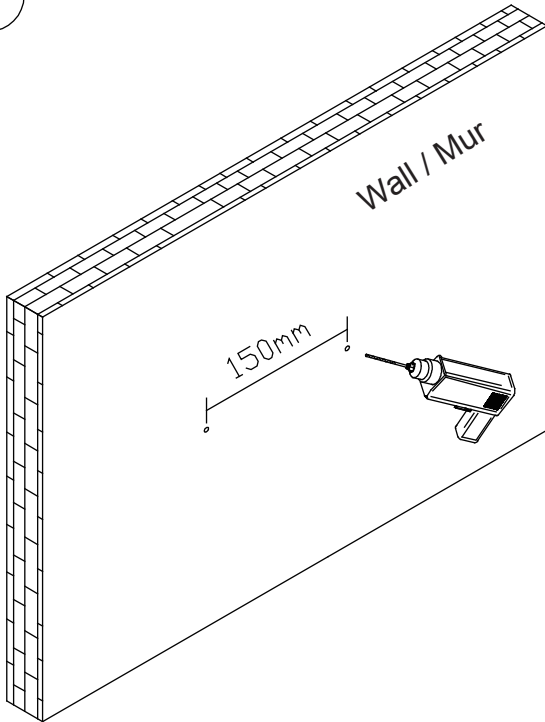

2

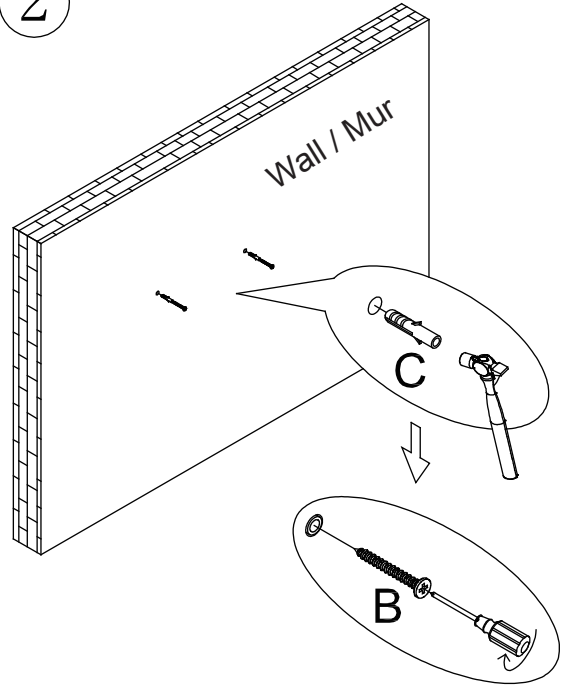

3

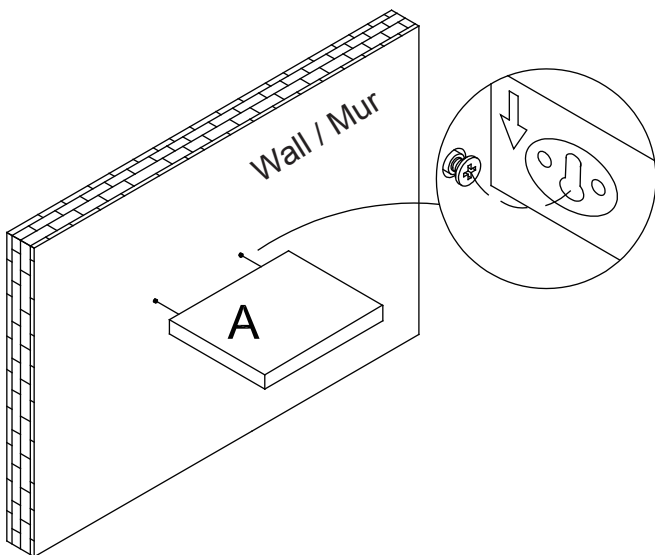

4

